

REVISION HISTORY - ALL SHEETS ARE THE SAME REV STATUS			
REV	ZONE	REVISION DESCRIPTION	ECN CODE
A		INITIAL RELEASED	

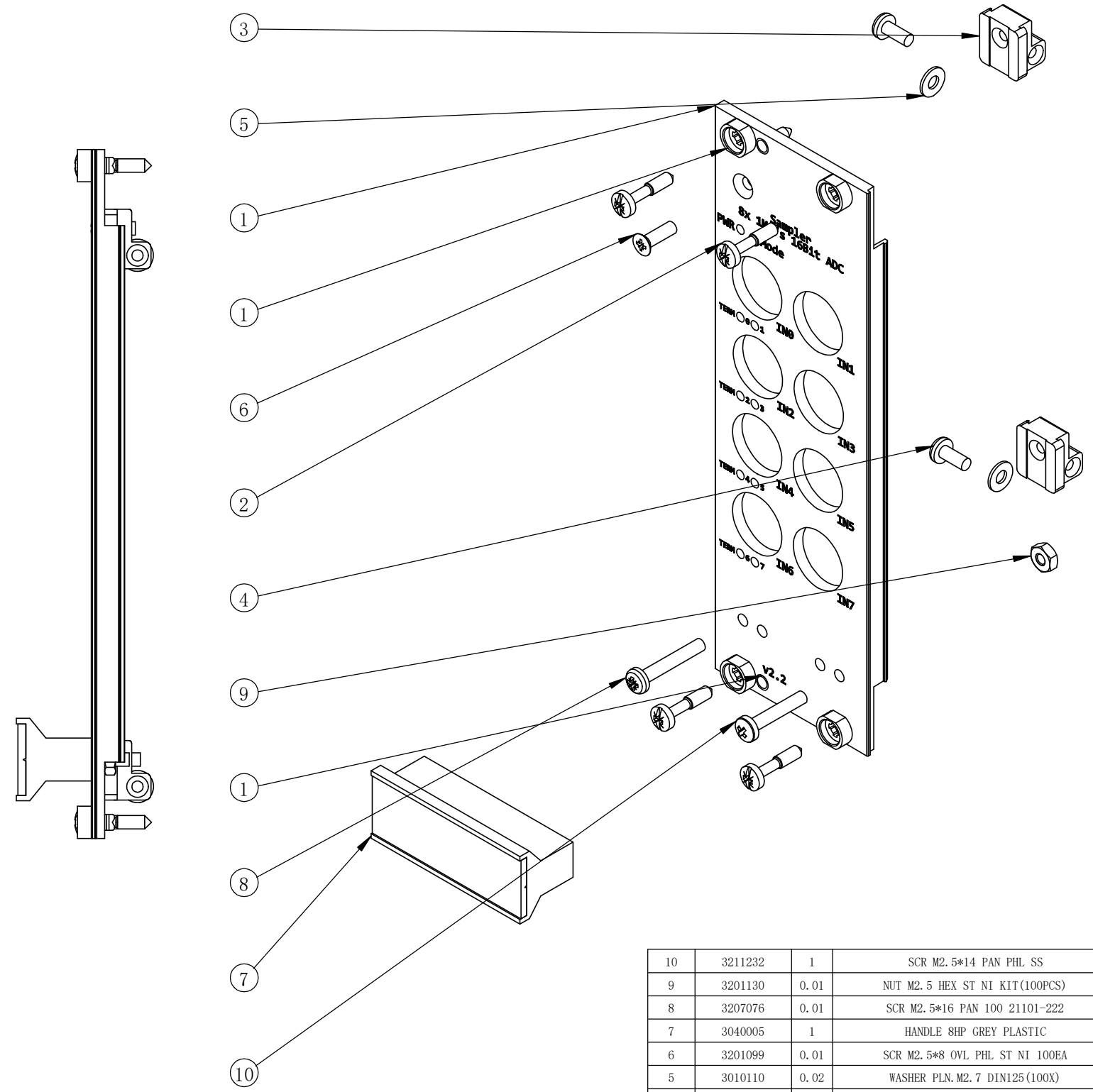
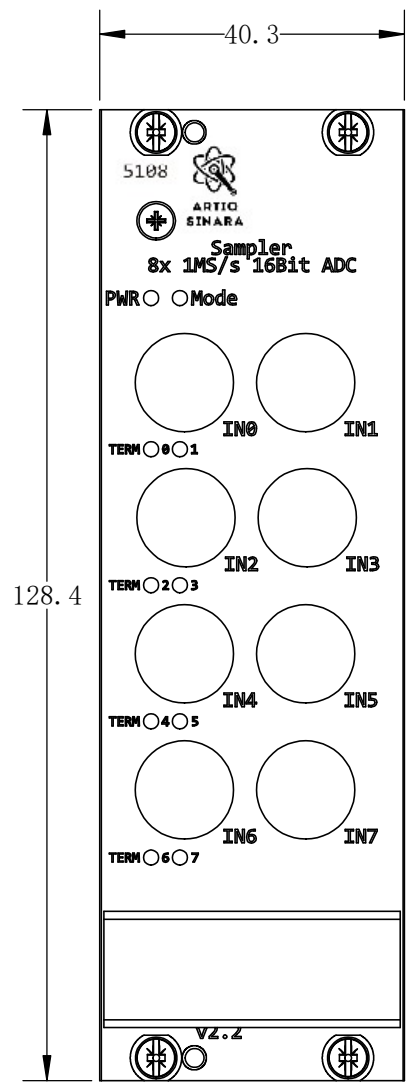

INDEX	PART NUMBER	QTY	DESCRIPTION	Note
10	3211232	1	SCR M2. 5*14 PAN PHL SS	
9	3201130	0.01	NUT M2. 5 HEX ST NI KIT(100PCS)	
8	3207076	0.01	SCR M2. 5*16 PAN 100 21101-222	
7	3040005	1	HANDLE 8HP GREY PLASTIC	
6	3201099	0.01	SCR M2. 5*8 OVL PHL ST NI 100EA	
5	3010110	0.02	WASHER PLN. M2. 7 DIN125 (100X)	
4	3001012	2	SCR M2. 5*6 PAN PHL NI DIN7985	
3	3040138	2	PB HOLDER DIE-CAST	
2	3033098	0.04	SCREW COLLAR M2. 5X12. 3(100X)	
1	90504202	1	FP-LYKJ 3U8HP PANEL	

BILL OF MATERIAL				
Project Name: FP		Finish:		
Scale: 1:1		Material: NA THK: mm		
Description:		SOLIDWORKS		
FP-LYKJ 3U8HP PANEL ASSY				
Drawing Number:		Sh Pg		
FPPU0308E131M0023		1 1		
REF NO:	MASS (kg)	0.0273	REV	A

	Date	Name
Approved by	2021/1/14	Evan
Designed by	2021/1/14	Dongyang, Li
Drawn by	2021/1/14	Dongyang, Li
Checked by	2021/1/14	Randy

THIS DOCUMENT AND ANY ASSOCIATED DATA
 CONTAINS RESTRICTED INFORMATION.
 THAT IS MEANT PROPERTY.
 DO NOT DISCLOSE TO OR REPRODUCE
 FOR OTHERS EXCEPT AS AUTHORIZED BY NVENT.

默认线性公差表			
0	< X ≤ 6	±0.1	
6	< X ≤ 30	±0.2	
30	< X ≤ 120	±0.3	
120	< X ≤ 400	±0.5	
400	< X ≤ 1000	±0.8	
1000	< X ≤ 2000	±1.2	
角度公差 ±0.5°			

技术要求:
 1. 尺寸单位为毫米。除非特别标出,线性尺寸公差为ISO 2768-M
 下面要求除外:
 +/-0.15 定制铣加工开孔特征距离参考轮廓
 +/-0.1 任意开孔之间的距离
 +/-0.1 开孔尺寸
 形位公差参考 ISO 2768-K;
 2. 清除毛刺和锐利边;
 3. 所有标出尺寸仅为制造, 组装和检验。几何形状特征以CAD文件为准;
 4. 所有工艺过程和原材料应符合RoHS。