

REVISION HISTORY - ALL SHEETS ARE THE SAME REV STATUS			
REV	ZONE	REVISION DESCRIPTION	ECN CODE
A		RELEASED	

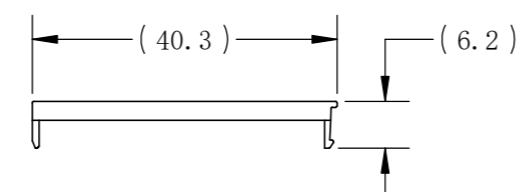
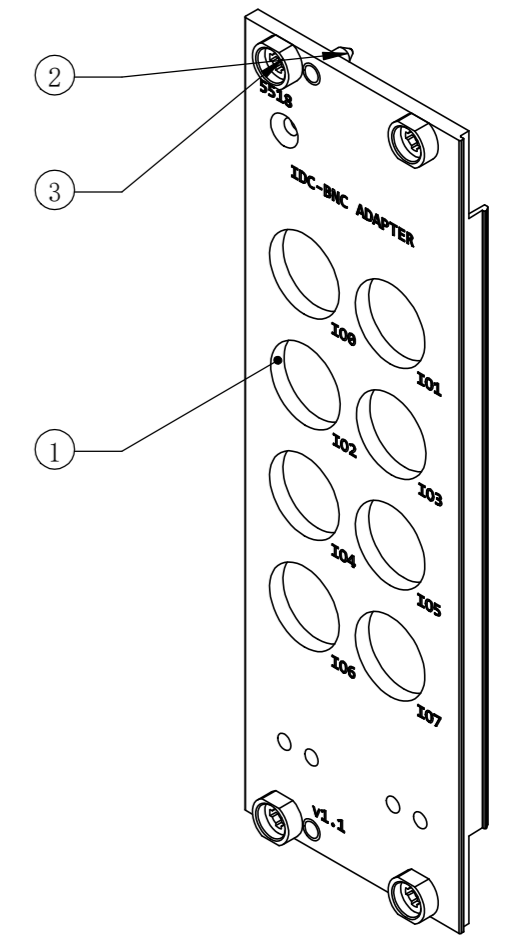
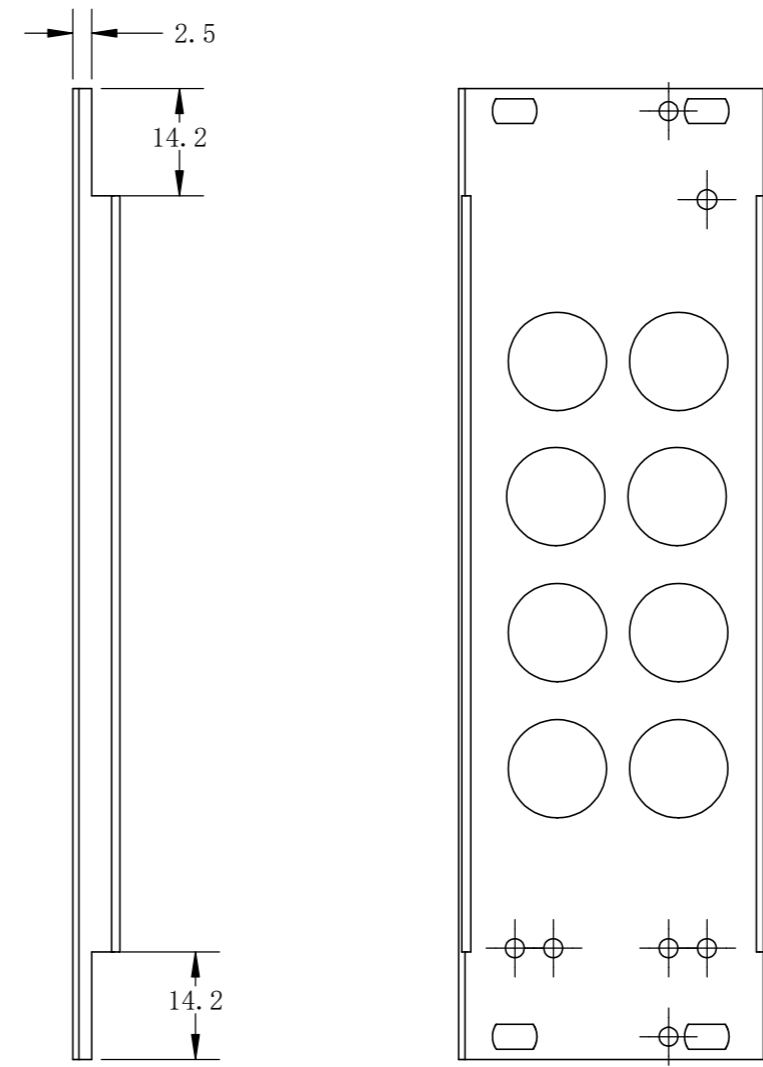
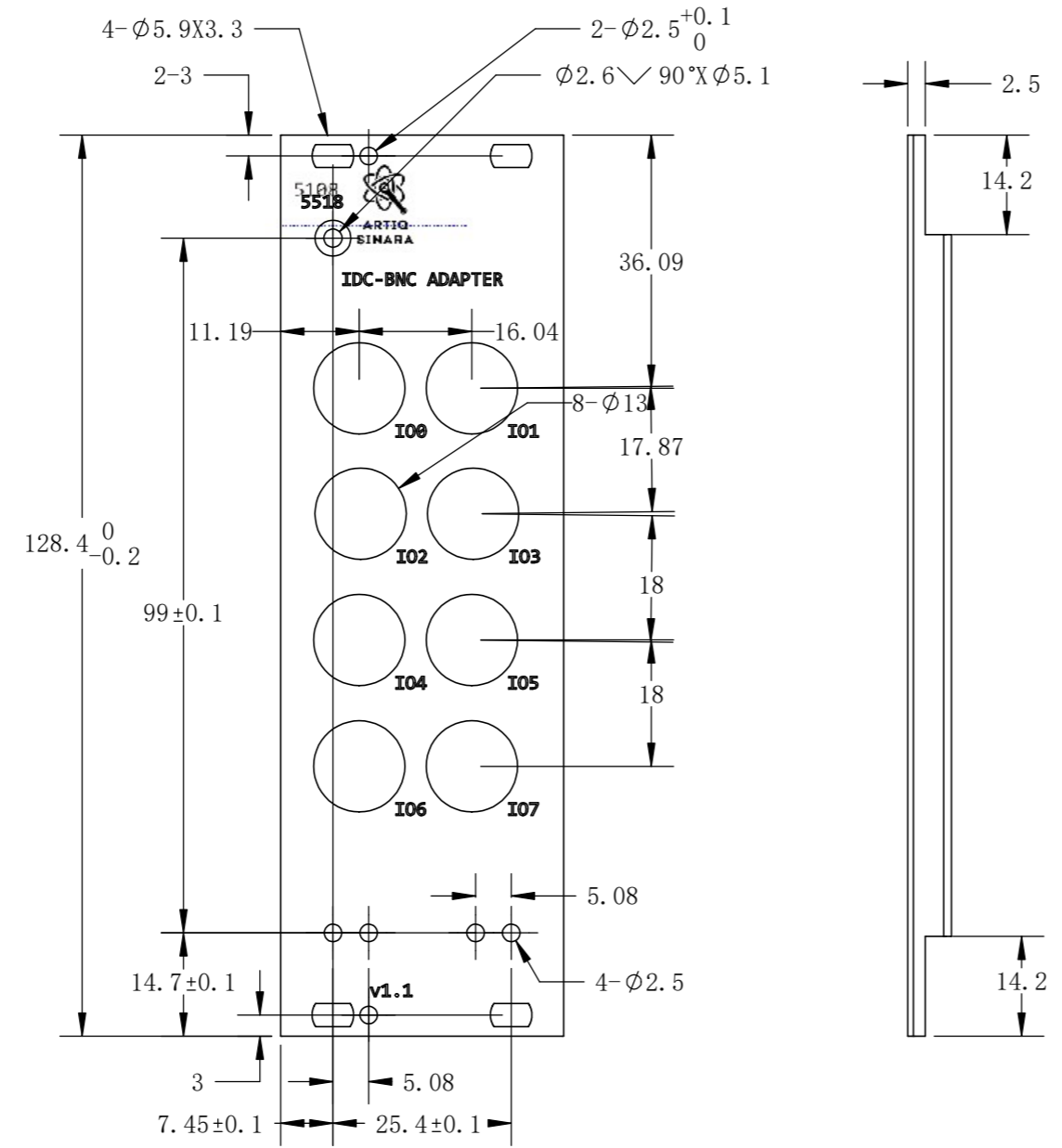

NOTES: UNLESS OTHERWISE SPECIFIED.  
 1. DIMENSIONS ARE IN MILLIMETERS, NON-LIMITED DIMENSIONS TOLERANCE, OTHER THAN THE SIZE OF RAW MATERIAL, SHALL BE HELD TO +/-0.2 EXCEPT AS FOLLOWS:  
 +/-0.15 FOR POSITION OF CUSTOMIZED MACHINING WITH REGARD TO REFERENCE EDGES  
 +/-0.1 FOR ANY DISTANCES BETWEEN CUT-OUTS  
 +/-0.1 FOR CUT-OUT DIMENSIONS  
 GEOMETRICAL TOLERANCES FOLLOWING ISO 2768-K  
 2. SURFACE FINISH: FRONT CLEAR ANODIZED, REAR CLEAR PASSIVATED  
 3. FRONT SURFACE: CLASS A, REMAINING SURFACES: CLASS B  
 4. ALL DIMENSIONS SHOWN ARE FOR FABRICATION, ASSY, AND VERIFICATION ONLY. GEOMETRY IS CONTROLLED AND MAINTAINED BY CAD FILE.  
 5. REMOVE ALL BURRS AND SHARP EDGES.  
 6. ALL PROCESSING / MATERIALS MUST COMPLY WITH 2002/95/EC RoHS.  
 7. EXTRUSION PROFILE DIMENSION REFER TO 65309-798.

INDEX	PART NUMBER	QTY	DESCRIPTION	REMARK
3	3020716	0.04	SLEEVE GREY PLAS. M2.5 ( 100PCS)	
2	3218843	2	FP-ALIGNMENT PIN (LOCALIZATION)	
1	90506946	1	FP-FRONT PANEL, EXTRUDED, TYPE 2, STATIC, 3Ux8HP	

BILL OF MATERIAL			
Project Name:	FRONT PANEL	Finish:	阳极氧化(7-12um) 电泳
Scale:	1:1	Material:	
Description:	FP-LYKJ 3U8HP PANEL		

Approved by	2021/1/14	Edison	Drawing Number: <b>90506946</b>	Sh 1	Pg 1	THIRD ANGLE PROJECTION	
Designed by	2021/1/14	Dongyang, Li					
Drawn by	2021/1/14	Dongyang, Li					
Checked by	2021/1/14	Randy	REF NO:	MASS (kg)	0.0115	REV	A

PENTAIR RESTRICTED  
 THIS DOCUMENT AND ANY ASSOCIATED DATA  
 CONTAIN PROPRIETARY INFORMATION.  
 THIS IS PENTAIR PROPERTY.  
 DO NOT REPRODUCE OR REPLICATE  
 FOR OTHERS EXCEPT AS AUTHORIZED BY PENTAIR