

Linus Woo Chun Kit

M-Labs Limited

Sheet: /analog supply/

File: asupply.kicad\_sch

**Title: analog supply**

Size: A3

Date: 2023-11-09

Rev: r0\_3

KiCad E.D.A. kicad-cli 7.0.7

Id: 5/8

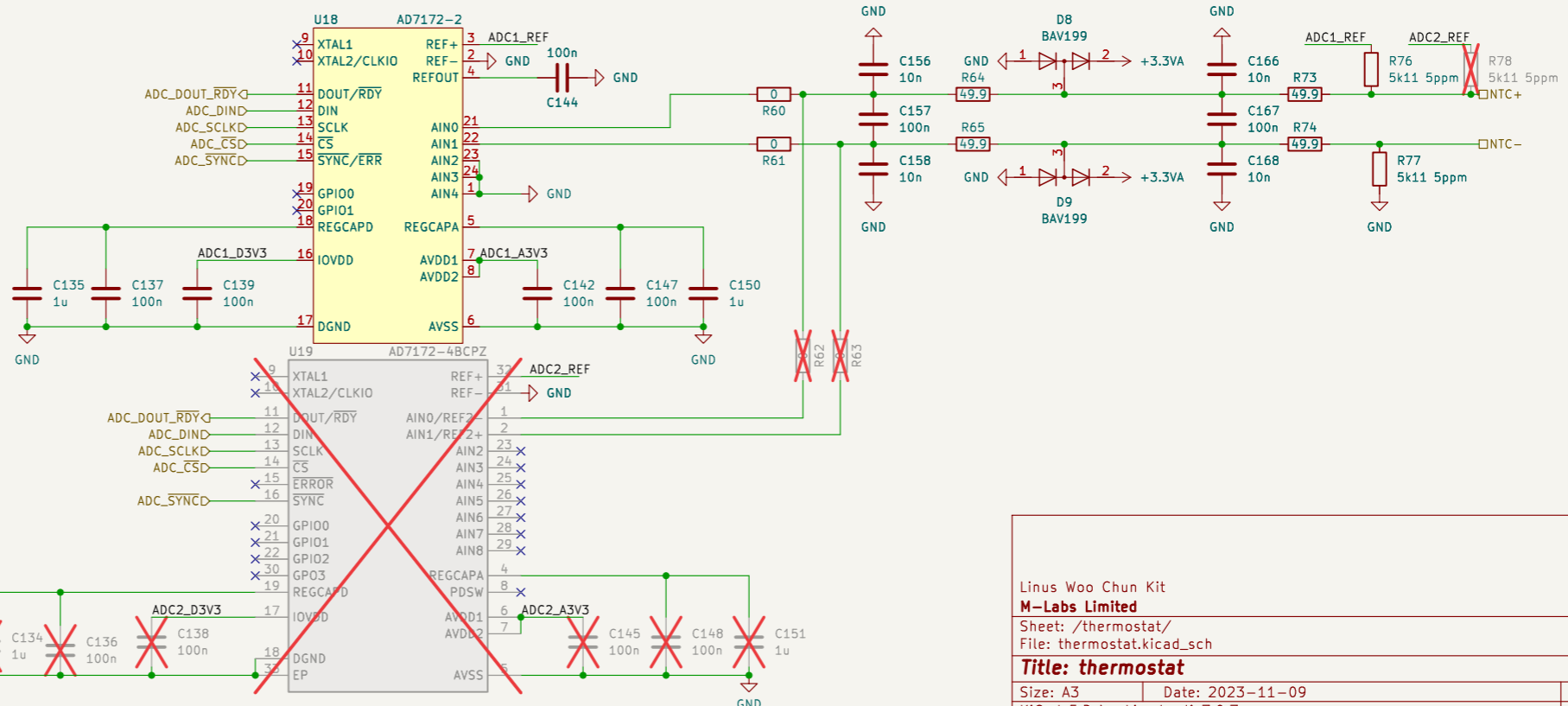
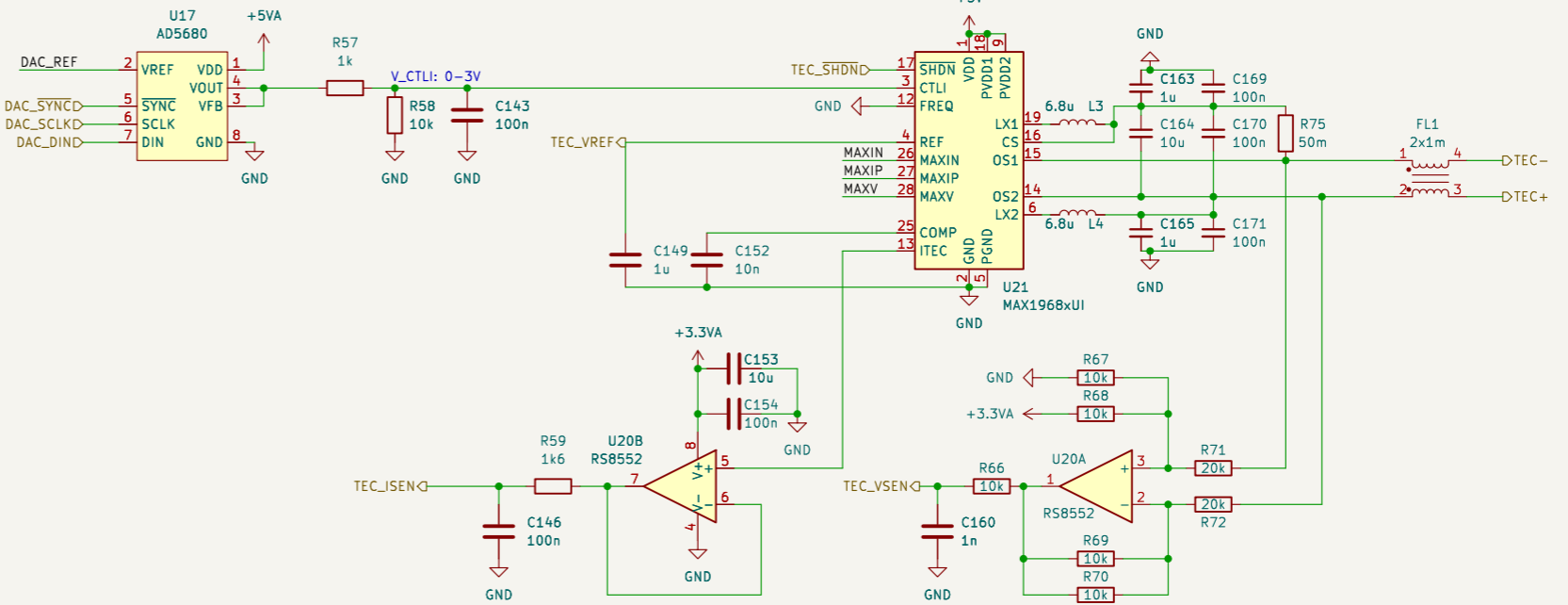
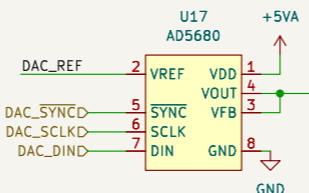
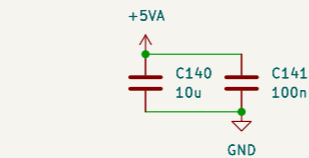
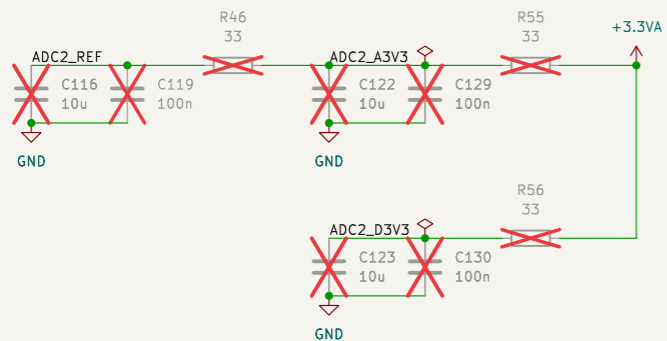
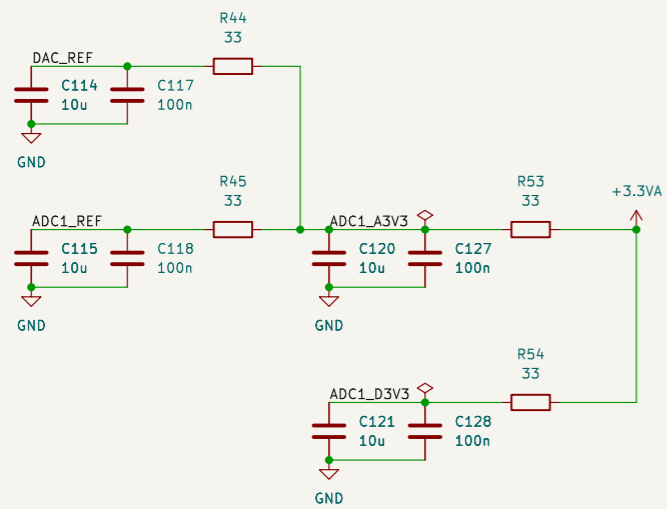
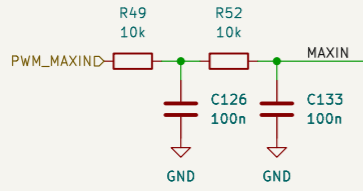
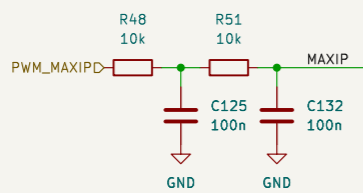
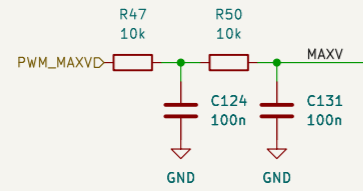

Linus Woo Chun Kit		
M-Labs Limited		
Sheet: /thermostat/		
File: thermostat.kicad_sch		
<b>Title: thermostat</b>		
Size: A3	Date: 2023-11-09	Rev: r0_3
KiCad E.D.A. kicad-cli 7.0.7		Id: 5/8

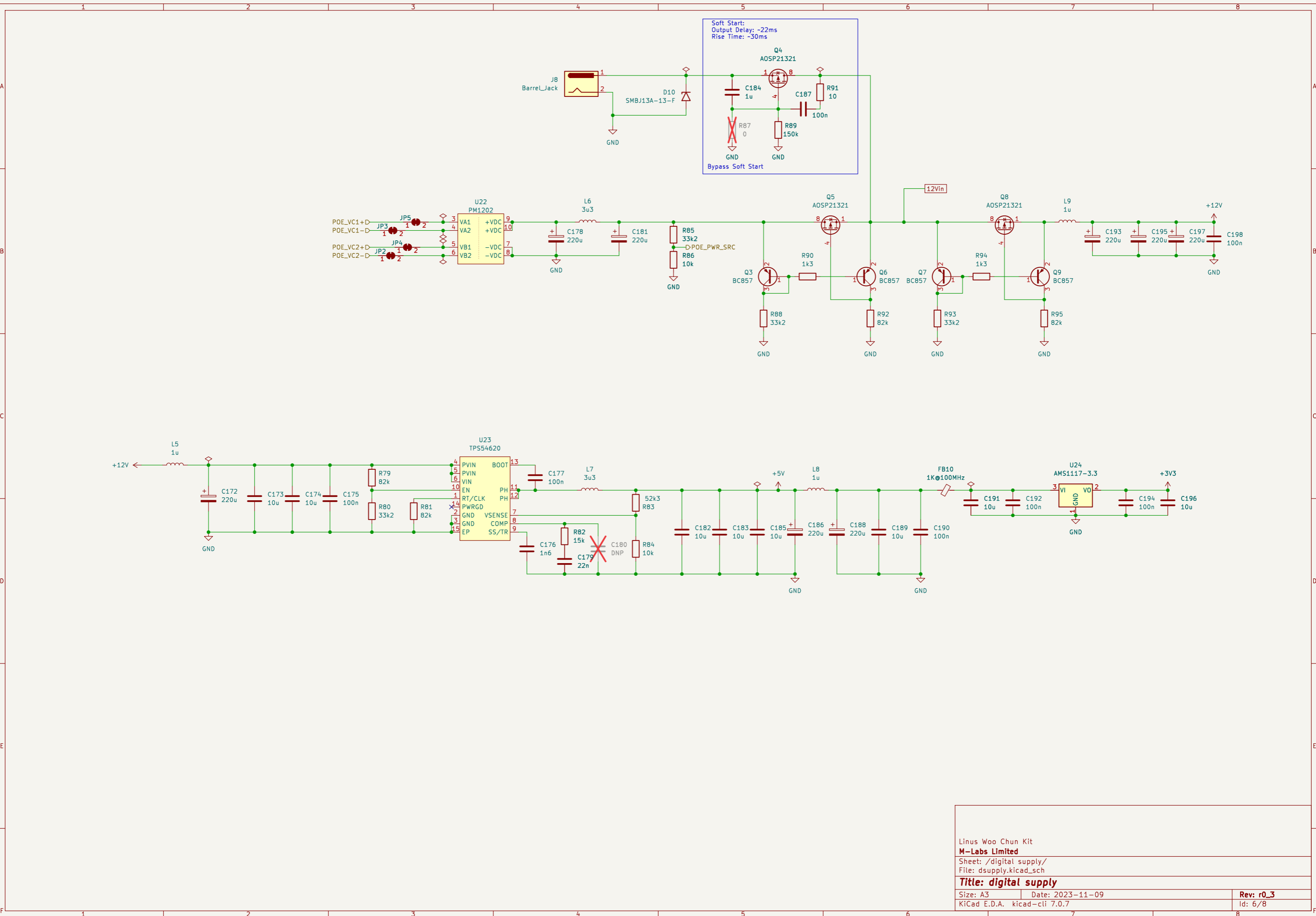

Linus Woo Chun Kit		
<b>M-Labs Limited</b>		
Sheet: /digital supply/		
File: dsupply.kicad_sch		
<b>Title: digital supply</b>		
Size: A3	Date: 2023-11-09	Rev: r0_3
KiCad E.D.A. kicad-cli 7.0.7		Id: 6/8

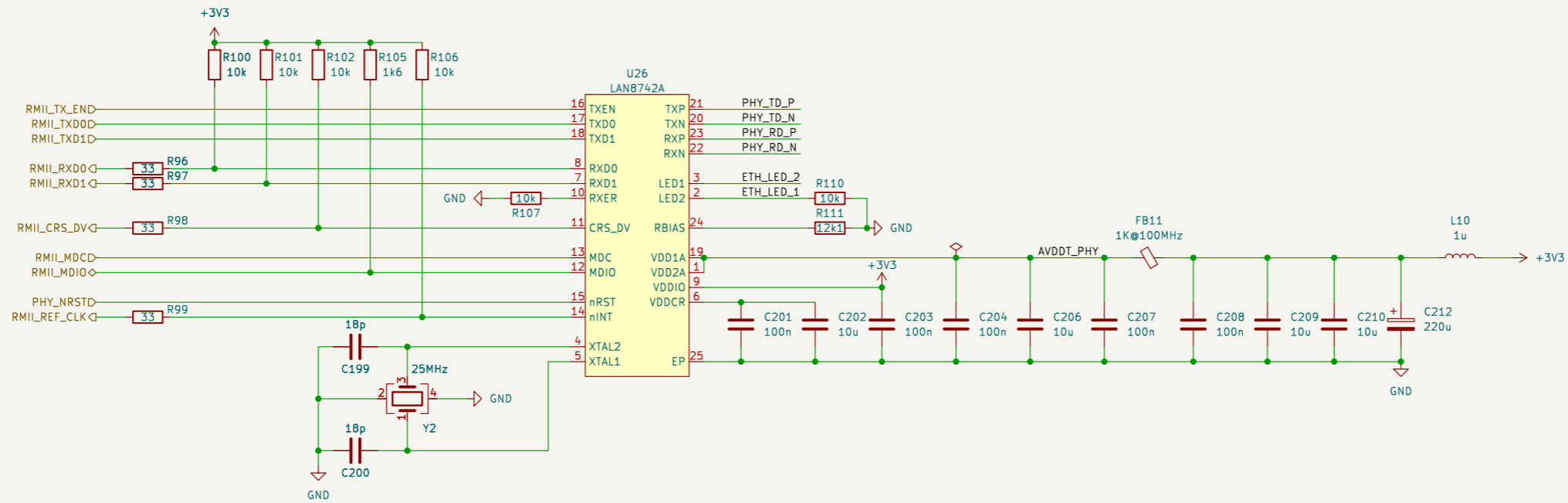
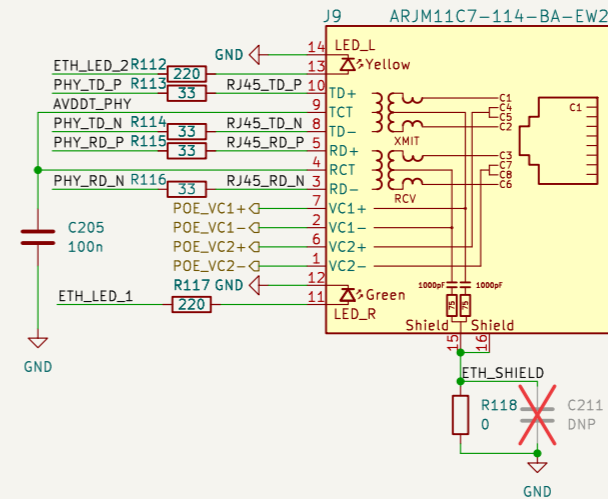
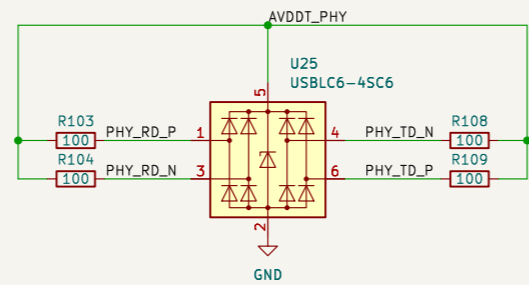

Linus Woo Chun Kit  
**M-Labs Limited**  
 Sheet: /Ethernet/  
 File: eth.kicad\_sch

**Title: Ethernet**

Size: A3 Date: 2023-11-09  
 KiCad E.D.A. kicad-cli 7.0.7

Rev: r0\_3  
 Id: 7/8

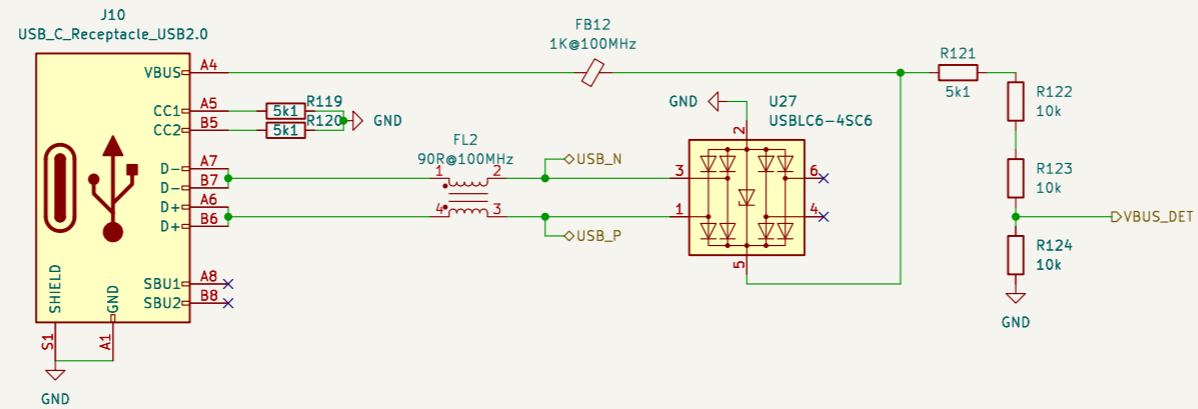

Linus Woo Chun Kit  
**M-Labs Limited**  
 Sheet: /USB/  
 File: usb.kicad\_sch

**Title: USB**

Size: A3 Date: 2023-11-09  
 KiCad E.D.A. kicad-cli 7.0.7

Rev: r0\_3  
 Id: 8/8